

HARDTAPE[®] INTERNAL BAYS



Innovative

The HardTape[®] Bay is designed to simplify the addition of high performance storage to any application. Slide the HardTape[®] Bay into your PC, server, rack, or tower and all you need to decide is what capacity HardTape cartridge to use. With “hot-swap” on some interfaces and steady-state transfer rates of 50+MB/s accessing, transporting and playing large audio, data and video files is easier than ever.

Standard

The HardTape[®] Bay is the same size as a floppy drive or 3.5” disk drive and utilizes standard side mounting holes. An optional 5¼” bracket kit is available allowing installation into CD/DVD slots. The power and data connectors are standard and drivers are not required for current operating systems making most installations, plug ‘n play. The “hot-swap” on some interfaces allows cartridges to be exchanged without a system shut down.

Flexible

The HardTape[®] Bay allows OEM’s, system integrators, and designers the ability to incorporate removable storage. Fixed drives are easily replaced with removable drives and multiple bays can be added allowing scaling of total storage capacity. Standard (IDE, SATA, USB, SCSI) and custom (Firewire, LVD SCSI) interfaces allows connection to almost any system



AUDAVI Corporation
1430 Tully Road; Suite 416
San Jose, CA 95122

Toll Free: 877-947-0830
Phone: 408-435-8100
Fax: 408-435-8101
Email: info@audavi.com
Website: www.audavi.com
CAGE: 3DJV2 DODAAC: Q92265

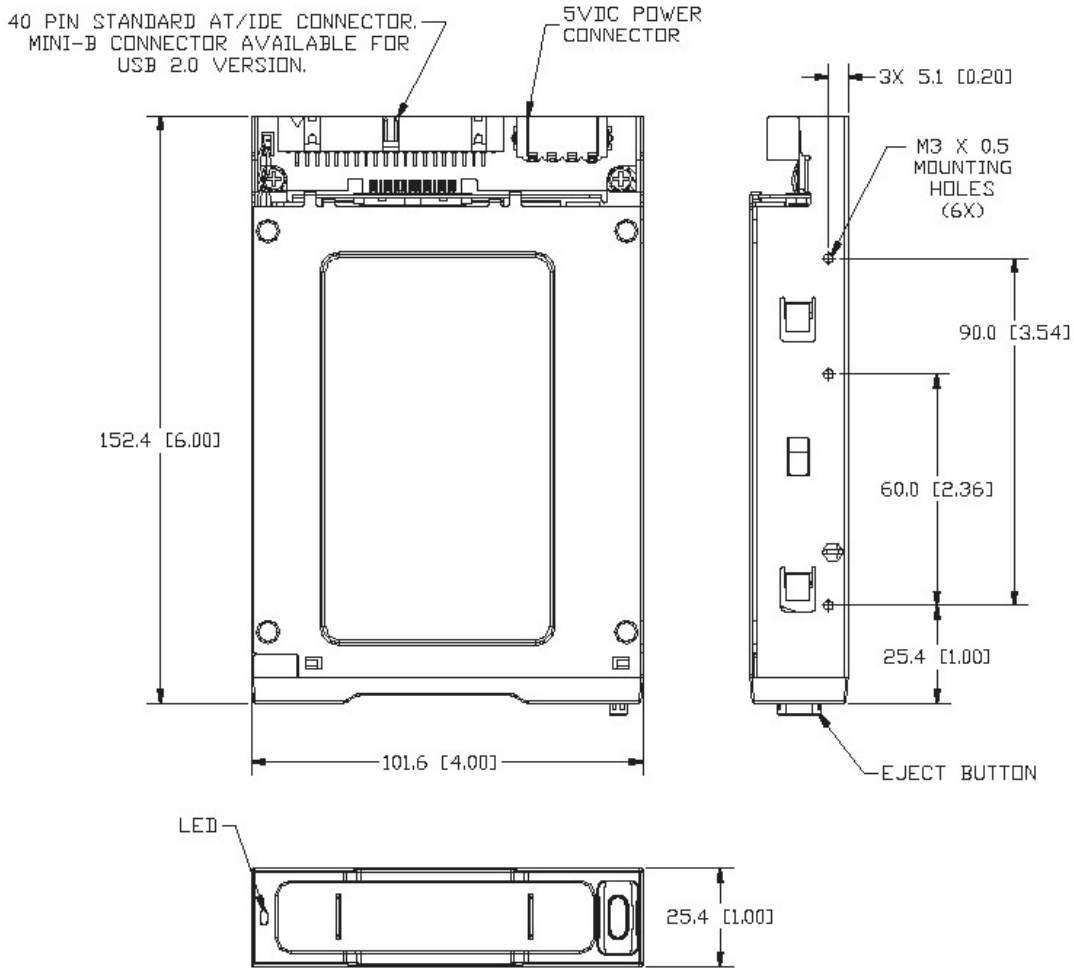

HardTape[®] Bay Key Metrics

	IDE	SATA*	USB	SCSI-50	SCSI-68
Dimensions (HxW)	1.0" x 4.0" / 25.4mm x 101.6mm				
Dimension (L) inches/mm	6.0 / 152.4	6.6 / 168.4	6.0 / 152.4	7.2 / 181.2	7.3 / 185.5
Weight (lbs/gms)	0.62 / 280	0.64 / 290	0.62 / 280	0.65 / 295	0.66 / 300
Power Requirement / Plug	5 VDC - Standard 4-pin Molex connector				
Data Interface Connector	Std 40-pin	Std 7-pin	Std 5-pin	Std-50-pin	Std 68-pin
Cartridge Connector Rating	10,000 insertion cycles				
Interface Transfer Rate	100 MB/s	150 MB/s	35 MB/s	20 MB/s	40 MB/s
"Hot-swap" Interface	No	Yes	Yes	"Warm"	"Warm"
Mounting / Data Connection	Side Mount w/ M3 x 0.5 - 4mm / Data cables not included except USB				

* SATA bay uses PATA to SATA interface card attached to standard IDE bay

"Warm" requires rescan of SCSI bus, but does not require system power shutdown.